

Installation Precautions:

1. Please read through the Instructions before installation and all note in Installation.
2. Although this product is a low-voltage product, please do not let children play with it.
3. Suitable for indoor dry places and cannot be installed in environments with water.
4. The use ambient temperature of LED tape is -20 °C -50 °C.
5. Make sure the power supply is cut off before installation and maintenance, to avoid the risk of electric shock.
6. When using a matching DC power supply, it is necessary to confirm the actual power consumption of the light strip, and then choose to use the corresponding power supply driver.
7. During the installation process, please pay attention to the polarity of the wiring and the working voltage requirements of the LED tape.
8. The actual total power of the LED tape cannot exceed 80% of the power of the connected power source.
9. It is recommended that the total length of the series connected light strip should not exceed 70W, otherwise the brightness difference between the head and tail will be significant. If necessary, please install it in parallel.
10. During use, it is necessary to ensure that there is no cover of flammable and explosive materials.

Power	Suggest connecting the maximum length in series
6W/M	11 M
10W/M	7 M
13W/M	5 M

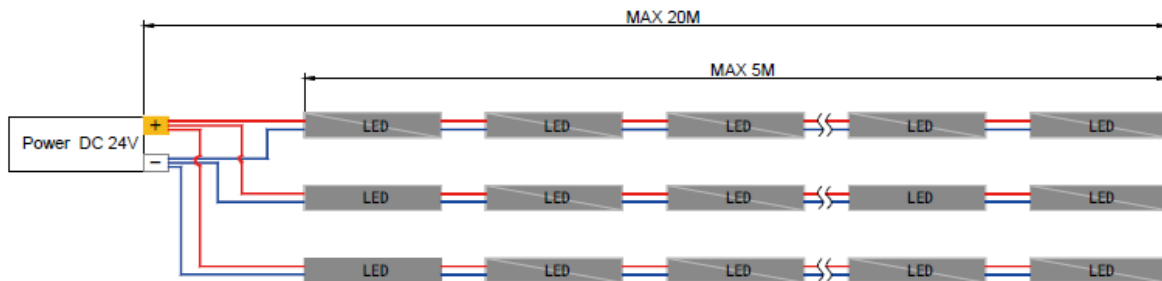

For an example DC24V 13W/M LED tape

Output polarity:

1. This type of product uses a 24V DC power supply. The red lead is connected to the positive pole "+" of the power supply, and the black lead is connected to the negative pole "-" of the power supply. (Except for special instructions) ;

Connect the black wire to the negative pole of the power supply, the red wire to the positive pole of the power supply

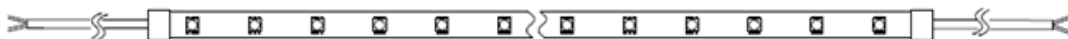

24V white light LED tape

Installation method:

Splicing method:

When splicing the LED tape with the LED tape, in order to ensure even light output from the LED tape, the tail of the sleeve should be stacked or staggered to ensure the same distance between the light beads, as shown in the following figure. When wiring, attention should be paid to polarity.

A. Using installation tracks.

- On a flat surface, such as wood.

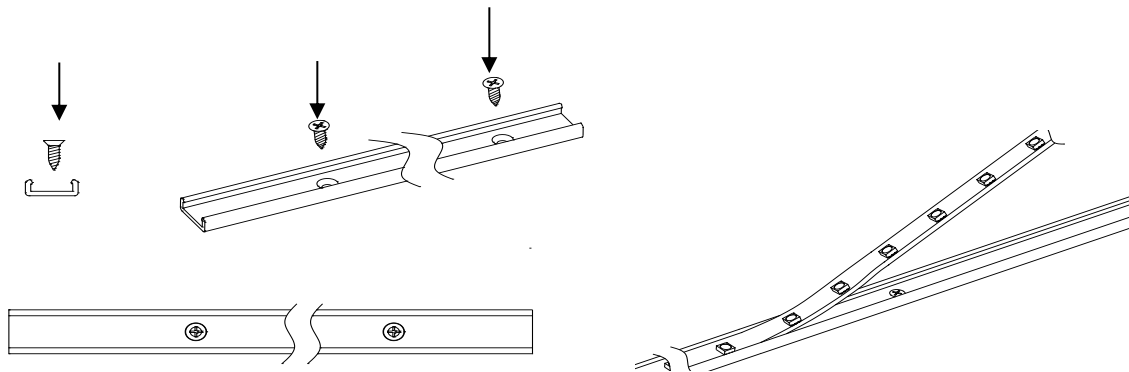

B. Using installation clip 1.

- Suitable for non flat installation surfaces, wood or concrete;
- There is space for two mounting screw holes on the installation surface;
- No edge contact installation requirements.

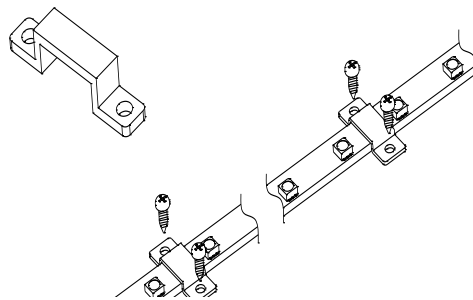

C. Using installation clip 2.

- Suitable for non flat installation surfaces, wood or concrete;
- Suitable for installation with contact on both sides of the light strip.

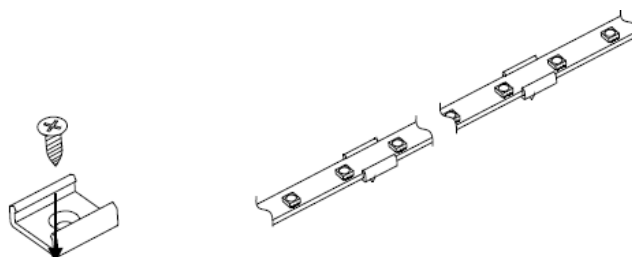

Cropping instructions:

1. When cutting the LED tape please cut it at the "scissor position" on the LED tape, otherwise it will cause the unit to not light up, and the cutting area needs to be covered with a tail plug for waterproof treatment. (As shown in the figure below);
2. After cutting the LED tape, special tools are needed to continue the tail of the cut LED tape. Please cut it carefully.

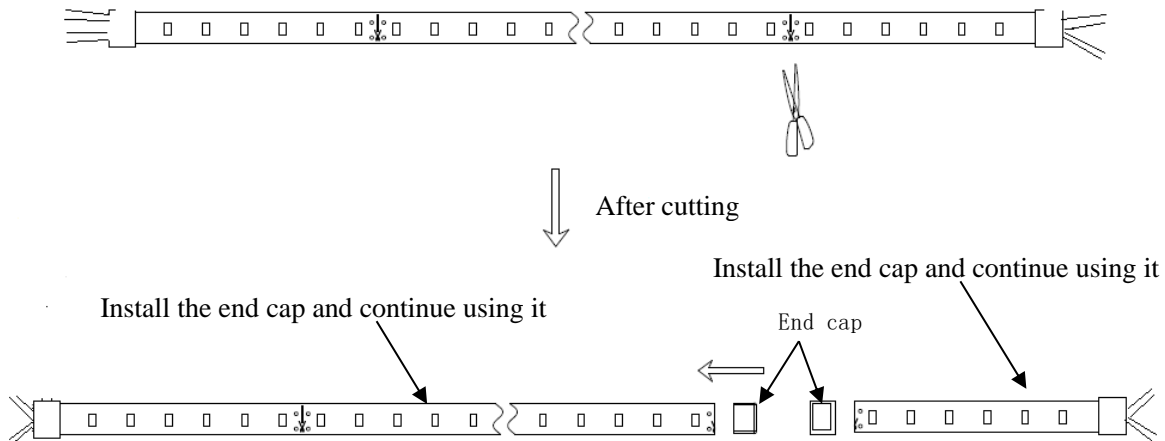

Note:

1. Choose a track with the appropriate size, gently press the blank area between the lamp beads and the LED tape track groove, and prohibit pressing or squeezing the lamp bead area from the front or side;
2. During the installation process, the bending radius of the LED tape is greater than 30mm and cannot be forcefully bent at right angles. When taking the LED tape during the installation process, it is prohibited to fold, twist, or forcefully twist it. If the LED tape is damaged due to human factors or improper rail selection during the installation process, our company will not be responsible;



3. The LED bead BIN area (using A, B, C, D, etc.) is selected for the identification of the LED tape itself. During installation, please pay attention to using the same BIN area identification as much as possible in the same area, so as to maintain the overall uniformity and uniformity of the light color of the LED tape in the same area.