

Installation Precautions:

1. Please read all instructions and installation precautions carefully.
2. For indoor use only (not suitable for damp locations).
3. Installation and testing of the luminaire must be performed by qualified professionals.
4. Disconnect the power supply before installation to prevent electric shock.
5. Retain this manual for future reference.

Light Installation:

1. The distance between the luminaire and the wall $L = 150 \text{ mm} - 300 \text{ mm}$. Secure the bracket to the ceiling with locking screws as illustrated. For multiple brackets, distribute them evenly along the luminaire body.

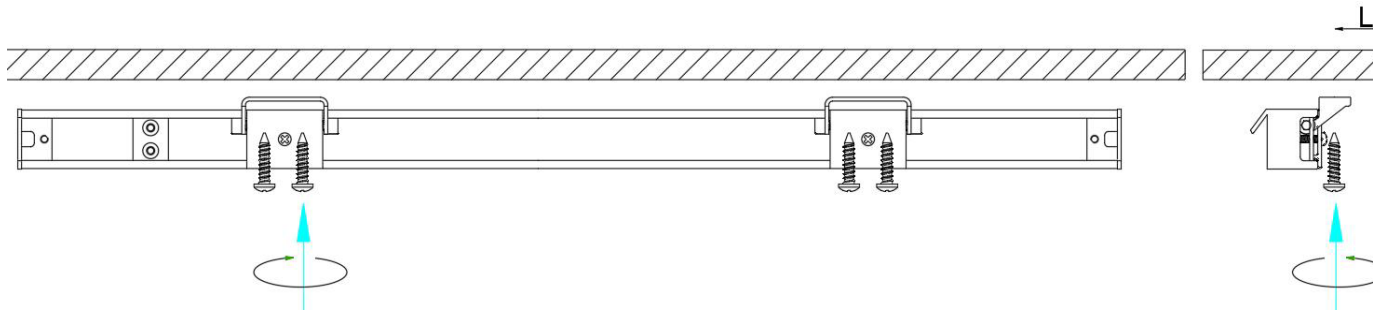

2. Connect the power cord to the terminal block according to the labeling. Note: Do not connect to high voltage without a driver.

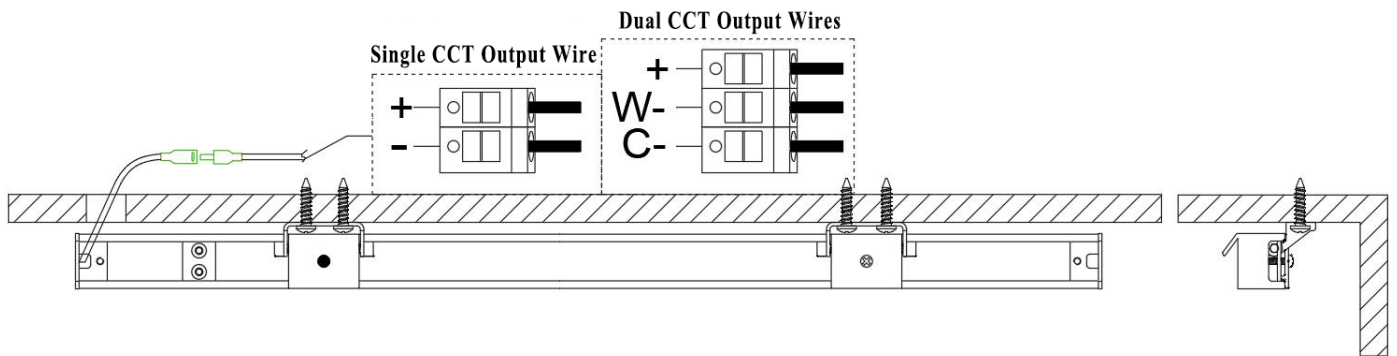

3. After fixing the bracket, rotate the luminaire body by 90° to complete installation.

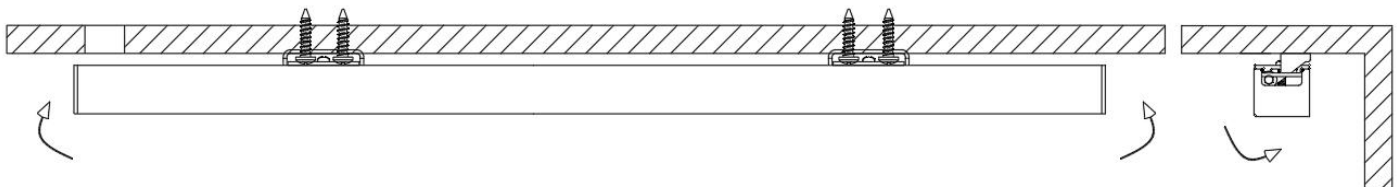

4. Luminaire Connection: Connect two light source modules using the male and female power cords.

Mate male and female plugs

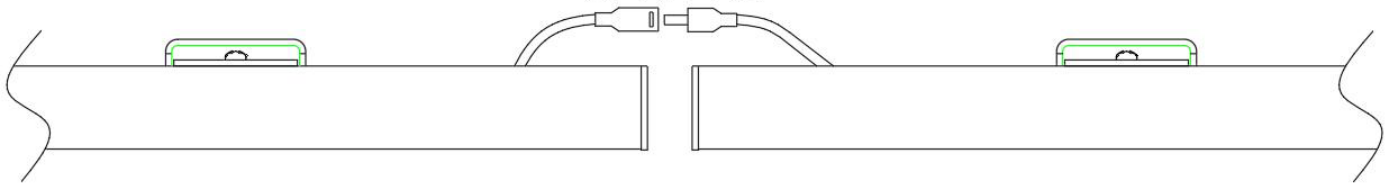

5. If the luminaire is equipped with a honeycomb louver, install as illustrated:

(1) Pull the cover out from the side.



(2) Insert the honeycomb louver into the luminaire body, align all edges properly, then slide the cover in from the side.

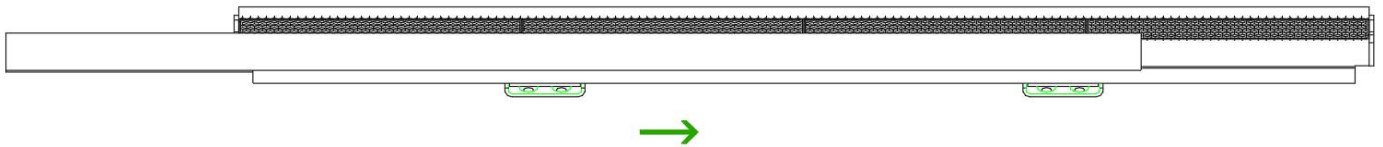

(3) Installation is now complete.

