

FQ

2" New Construction Housing

R2FBNT | R2FRNL | R2FSNL | R2FBFT

Fixture Type: _____

Project: _____

Catalog#: _____

Location: _____



LINE DRAWING

Trimmed and Trimless
New Construction

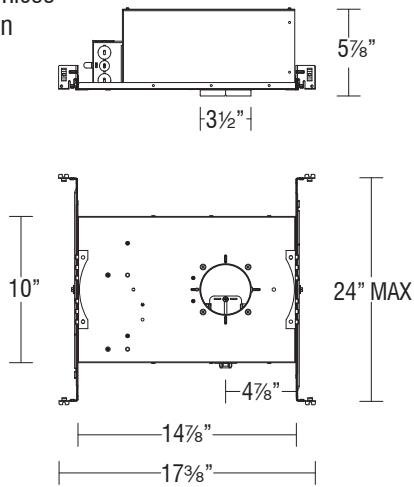

Trimmed Frame-In Kit

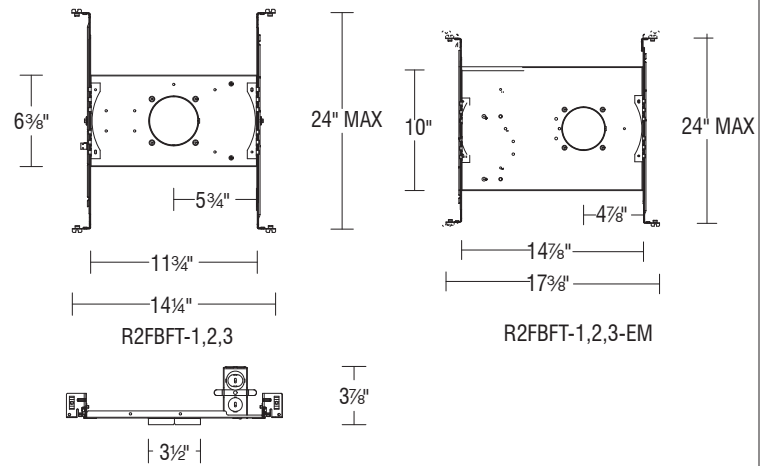

PRODUCT DESCRIPTION

The FQ Recessed series offers a complete line of high performance LED luminaires that provide outstanding functionality and quality. The FQ series features superlative glare control with 30° shielding, 35° vertical tilting, and uniform floor-to-ceiling wall washing. Multiple power level options and a full line of round and square, trimmed and trimless luminaires offer versatile solutions for various lighting applications. Easy to order, install, and service.

SPECIFICATIONS

Mounting:	New construction housings include universal mounting brackets and hanger bars Ceiling cut out (Round): $\varnothing 3\frac{1}{2}"$ Ceiling cut out (Square): $3\frac{1}{2}" \times 3\frac{1}{2}"$ □ Accommodates $\frac{1}{2}" - 1"$ ceiling thickness
Input:	Universal 120-277V AC, 50/60 Hz
Dimming:	ELV, TRIAC, 0-10V: 100 - 1%
Emergency:	EM fixtures provided with integral emergency battery backup with 24" lead wire remote test switch. Provides a minimum of 90 minutes of 6W illumination during emergency operation.
Standards:	ETL & cETL, IC-rated, Airtight, SPCL (Spray Foam Compatible Luminaire), up to R6.8 per inch, as per UL 1598
Warranty:	5 year WAC Lighting guaranteed warranty

FQ

2" New Construction Housing

R2FBNT | R2FRNL | R2FSNL | R2FBFT

Fixture Type: _____

Project: _____

Catalog#: _____

Location: _____

ORDERING INFORMATION

HOUSINGS				
	Model	Power	Rating	Emergency Backup*
New Construction Airtight - Round & Square Trim	R2FBNT	1 15W	IC, SPCL	EM <i>Optional</i>
		2 21W	IC	
		3 25W	Non-IC	
New Construction Airtight - Round Trimless	R2FRNL	1 15W	IC, SPCL	N/A
		2 21W	IC	
		3 25W	Non-IC	
New Construction Airtight - Square Trimless	R2FSNL	1 15W	IC, SPCL	N/A
		2 21W	IC	
		3 25W	Non-IC	
New Construction Frame-in Trimmed	R2FBFT	1 15W	Non-IC	EM <i>Optional</i>
		2 21W	Non-IC	
		3 25W	Non-IC	

R2F _ _ _

Example: R2FBNT-1 or R2FBNT-1-EM (with Emergency backup battery)

*EM option is not SPCL rated

Housing Model	Power	Emergency Backup	Replacement Driver Model
R2FBNT	1 15W	None	D-R2FN-1
R2FRNL	2 21W		D-R2FN-2
R2FSNL	3 25W		D-R2FN-3
R2FBFT	1 15W	None	D-R2FF-1
	2 21W		D-R2FF-2
	3 25W		D-R2FF-3
R2FBNT	1 15W	EM	D-R2FN-1-EM
R2FBNT	2 21W		D-R2FN-2-EM
R2FBFT	3 25W		D-R2FN-3-EM